

MERCURY2 PRO SERIES

ME2P-1230-9GM/C-P-VF8

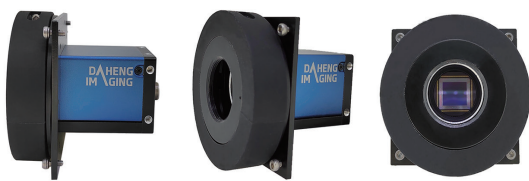

- Tilt-Shift Camera (vertical)
- Scheimpflug angle adjusting mechanism
- 1.1" global shutter CMOS sensor
- 12.3 Megapixels
- High definition, high quality image
- Multiple functions
- Power over Ethernet (PoE)

The MERCURY2 PRO PoE series (ME2P-G-P) camera is DAHENG IMAGING's high definition industrial digital camera, featuring outstanding performance, high quality image, multiple functions and flexible installation.

ME2P-1230-9GM/C-P-VF8 is a monochrome/color Tilt-Shift Camera with the Sony IMX304 CMOS sensor. When the object is not parallel to the sensor, the vertical angle between lens and sensor plane can be adjusted from 0 to 8 degree to increase the depth of field. Four-side mounting holes provide maximum installation flexibility for ME2P-G-P, the MERCURY2 PRO PoE series cameras can secure the reliability of cameras deployed in harsh environments.

Featuring compact design, outstanding performance, ease of installation and use, the MERCURY2 PRO cameras are especially suitable for machine vision applications such as industrial inspection, medical, scientific research, education, security and so on.

Features

- The vertical angle between lens and sensor plane can be adjusted from 0 to 8 degree
- Two exposure time modes: standard exposure time mode / minimal exposure time mode
- Gain, exposure and white balance programmable (white balance only for color models)
- Support auto gain, auto exposure and auto white balance (auto white balance only for color models)
- Four acquisition controls: Single frame acquisition/Continuous acquisition/Software trigger acquisition/External trigger acquisition
- Trigger mode: Frame Start /Frame Burst Start
- Support Timed exposure mode and TriggerWidth exposure mode
- Support Timer, Counter, LUTs and storable user sets
- Support Gamma, Sharpness, Black Level, Static Defect Pixel Correction and Flat Field Correction
- Support Decimation, Binning, Digital Shift and Reverse X/Y (horizontal and vertical mirroring)
- Mono models support Noise Reduction
- Color models support light source preset function, Color Transformation Control and Saturation function.
- Support Remove Parameter Limit to expand the range of exposure, gain, white balance, and so on
- Adjustable packet-size and packet-delay, and reserved bandwidth
- 16KB data storage area for saving algorithm coefficients and parameter configuration
- Compatible with GenICam™ and GigE Vision®, can be used in a wide range of 3rd-party software such as HALCON, MERLIC and LabVIEW directly
- Optimized software package for 32/64bit Windows, and support Linux, ARMv7, ARMv8 and Mac OS
- Multiple samples and easy-to-integrate SDKs for various programming tools
- Regulations: CE, RoHS, GenICam, GigE Vision, IEEE802.3af (PoE)

Performance Specifications

Model	ME2P-1230-9GM/C-P-VF8
Interface	GigE
Resolution	4096(H) × 3000(V)
Frame rate	9 fps
Sensor	1.1", global shutter Sony IMX304 CMOS
Pixel size	3.45 μm × 3.45 μm
Pixel Bit Depth	8bit, 12bit
Spectrum	Monochrome / Color
Exposure time	36μs ~ 1s
Minimal exposure time	1us~100us

Mechanical Specifications

Weight	152g
Dimensions	63(W)x63(H)x65.13(L) mm

Technical Drawing

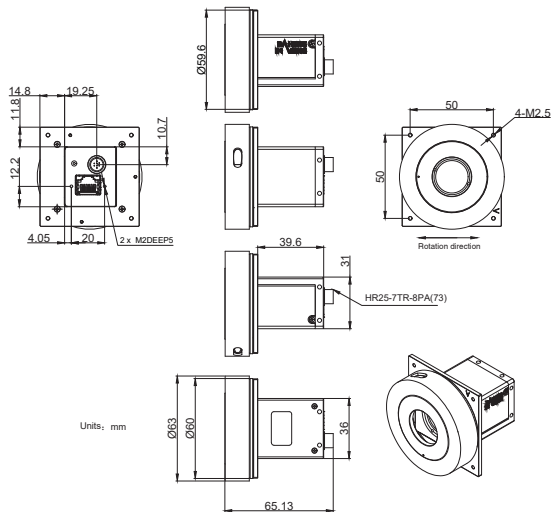

Electrical Specifications

Power requirement	12~24 VDC via 8-Pin or PoE
I/Os	1 input / 1 output, 2 GPIOs
Data interface	RJ45 with locked
Power consumption	<3W @24VDC; <3.75W @PoE

Environmental Specifications

Operating temp.	0°C ~ +45°C
Storage temp.	-20°C ~ +70°C
Operating humidity	10% ~ 80%

Optical Specifications

Lens mount	C-Mount (standard), CS-Mount (optional)
------------	-----------------------------------------

Spectral Response

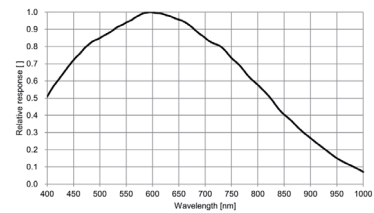

ME2P-1230-9GM-P-VF8

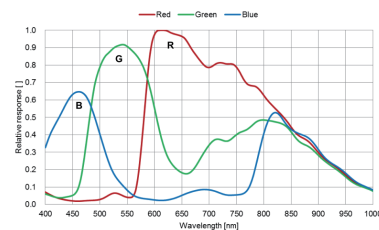

ME2P-1230-9GC-P-VF8

China Daheng Group, Inc. Beijing Image Vision Technology Branch

12F Daheng Science & Technology Tower, No.3 Suzhou Street, Haidian District,

Beijing China, 100080

Tel: +86 10 82828878

E-mail: isales@daheng-imaging.com

For more information please visit : www.daheng-imaging.com/en

Specifications are subject to change without prior notice.

Copyright © 2023 China Daheng Group, Inc. Beijing Image Vision Technology Branch. All rights reserved.

11030917